

JAC



# JAC FORKLIFT

H Series Internal Combustion  
Counterbalanced Forklift Truck

CPCD50H / CPCD60H / CPCD70H / CPCD80H / CPCD100H



**JAC** HEAVY DUTY IMPORT & EXPORT CO.,LTD







**MATERIAL HANDLING EXPERTS  
FROM AUTOMOTIVE QUALITY**



✉ [contact@gmm-mg.com](mailto:contact@gmm-mg.com)  
📍 Route du Pape Alarobia (face sanifer)  
☎ +261 32 03 111 33 / +261 32 03 111 34 / +261 32 03 111 36



**Move forward**



# Selling Points Of H Series 5-10t Internal Combustion Counterbalanced Forklift Trucks

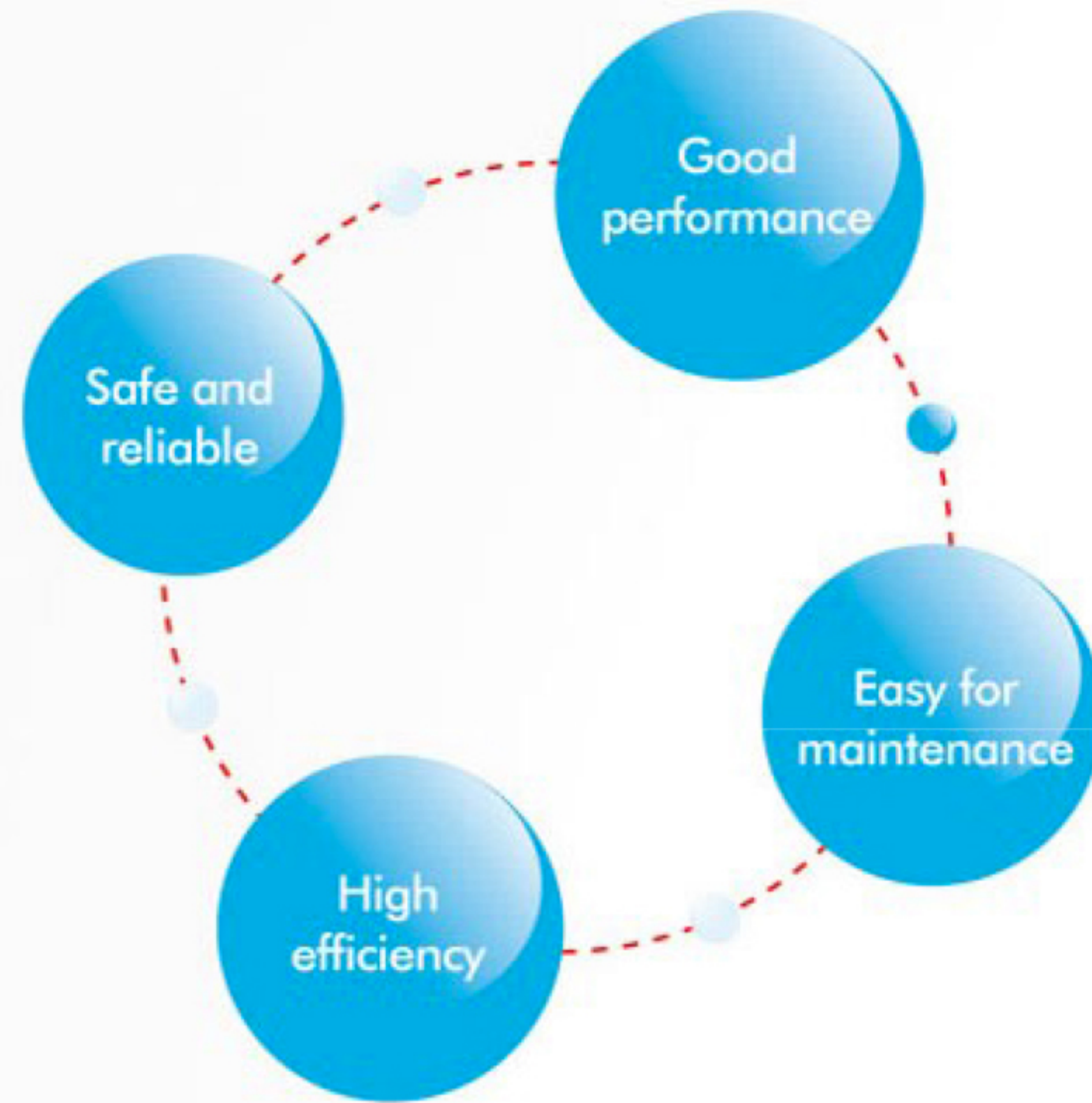

## Four Highlights

### No.1 Good performance

#### ◆ Delayed power-off—The first in China

The machine will be powered off in case the machine has been powered on but not in use for at least 10 minutes, which is safe and energy-saving.



#### ◆ Load sensing hydraulic system

Load-sensitive hydraulic system ensures the fork to lift with full load while the engine is running idly so as to reduce fuel consumption.

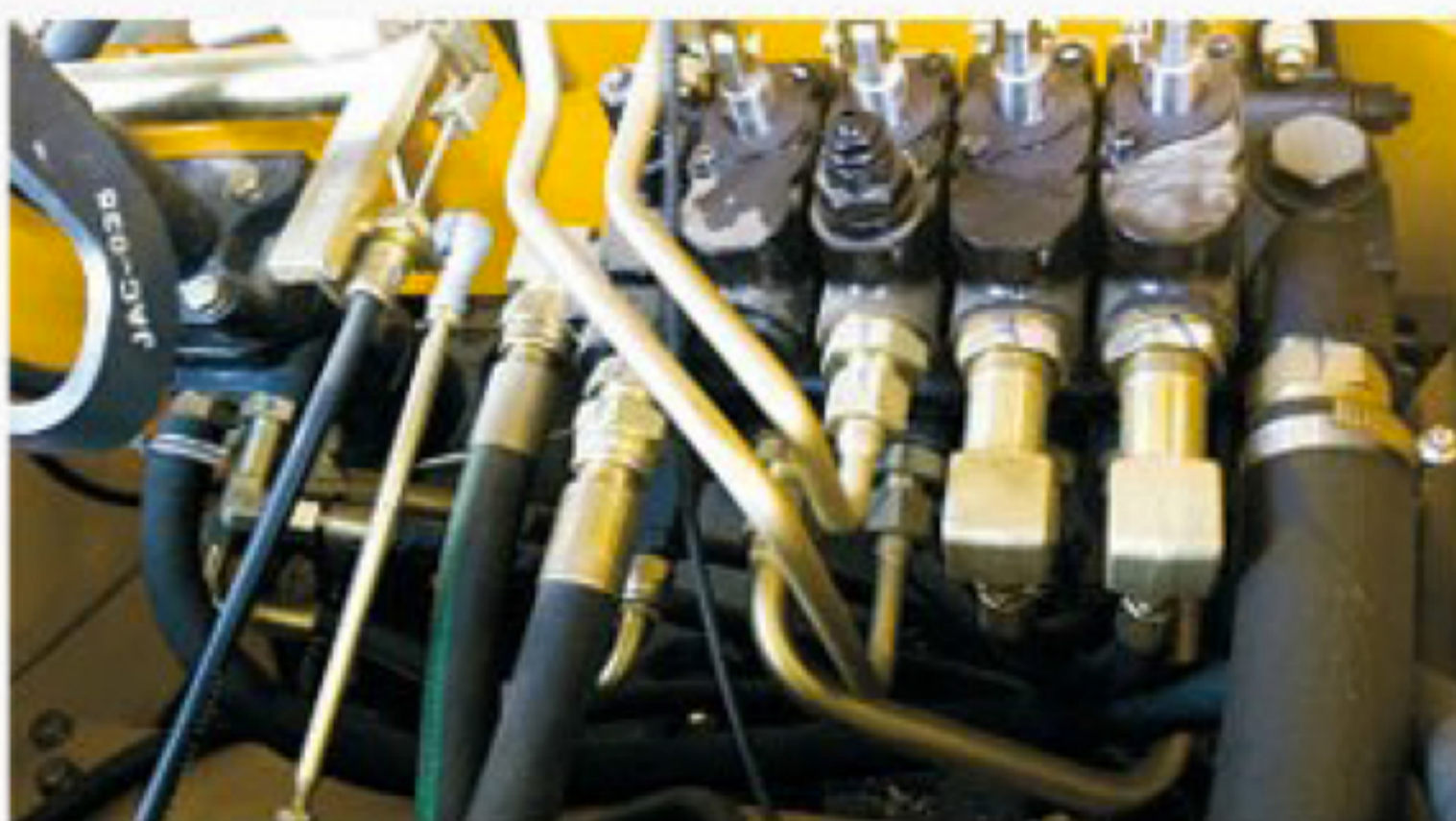

#### ◆ Improved longitudinal stability of the forklift

Stability is better than other products of same class.

#### ◆ Enhanced working unit

Load-sensitive hydraulic system ensures the fork to lift with full load while the engine is running idly so as to reduce fuel consumption.

#### ◆ Low speed ratio realizes traveling speed above 24KM/H.







## No.2 Safe and reliable

### ◆ Engine electrical system with water-proof connectors

The imported water-proof connectors are more reliable.

Water-proof grade Ip65

### ◆ 24° cone+Oring

The hydraulic system adopts the most advanced sealing.

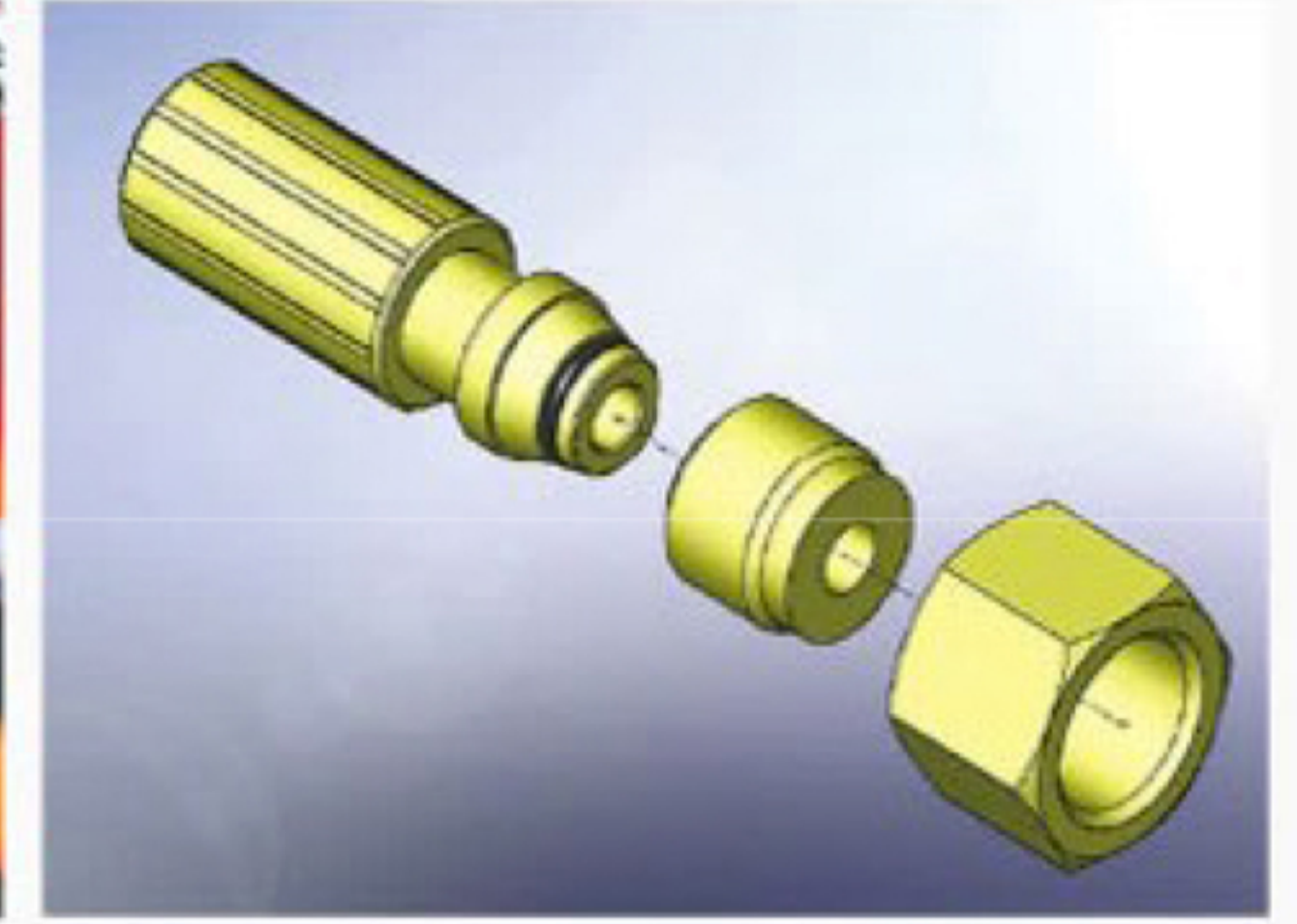
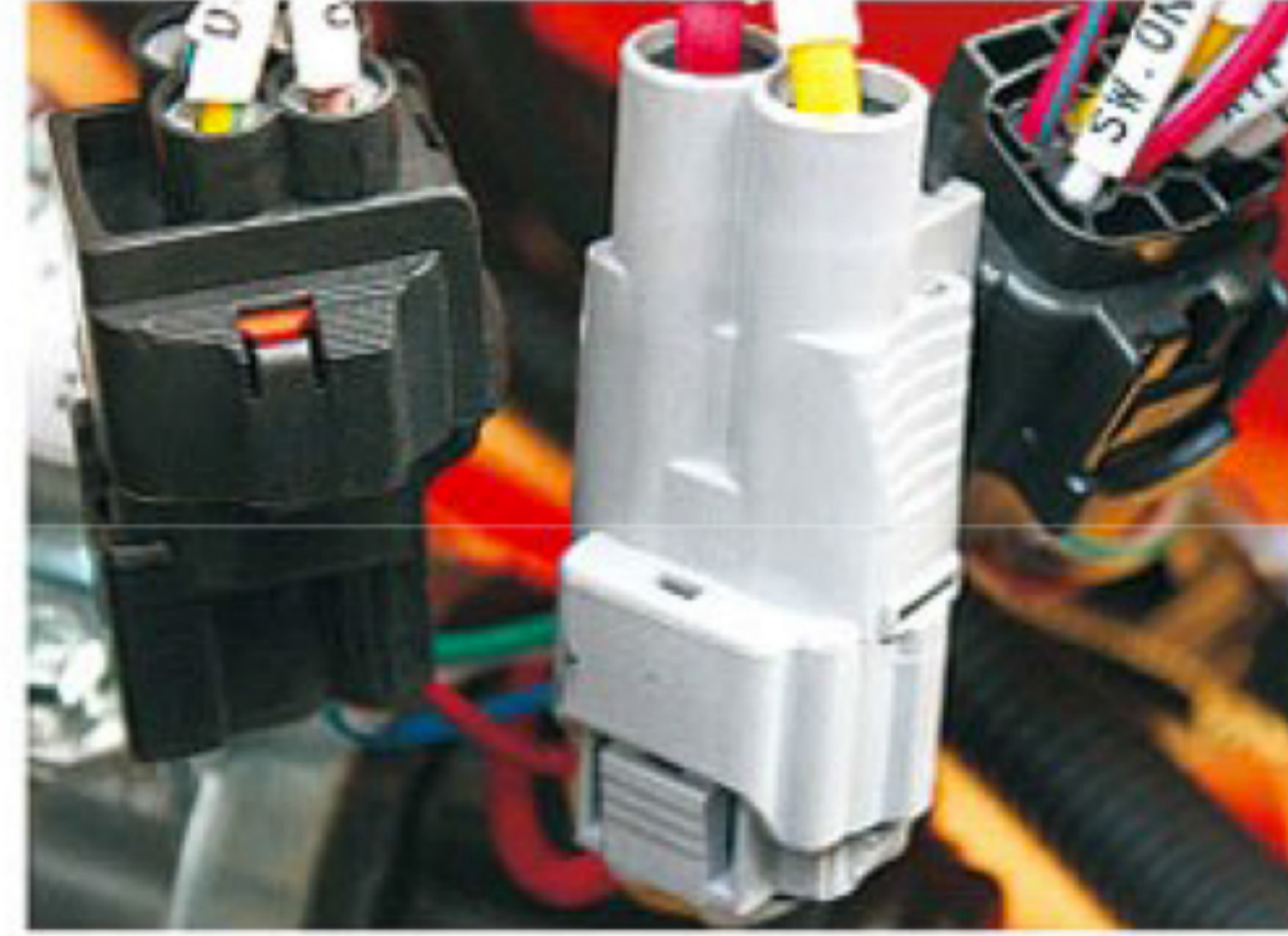

## No.3 High efficiency

### ◆ Spacious cab

Ergonomics-based design ensures easy operation.

### ◆ wide-view mast

Wide mast broadens visual field.



## No.4 Easy for maintenance

### ◆ Early-warning of instruments service is provided

Regular early-warning of instrument service realizes intelligent service.

### ◆ Large opening angle of engine hood

The engine hood can be lifted to 80° for easy maintenance.

### ◆ Foldaway coolant tank cover

The foldaway cover enables easy replenishment and maintenance.





# SPECIFICATIONS

Model			CPCD50H	CPCD60H	CPCD70H	CPCD80H	CPCD100H
1	Power type		Diesel	Diesel	Diesel	Diesel	Diesel
2	Rated load	kg	5000	6000	7000	8000	10000
3	Load center distance	mm	600	600	600	600	600
4	Lift height	mm	3000	3000	3000	3000	3000
5	Free lift height	mm	205	205	205	205	210
6	Fork size	L x W x T	1220 x 150 x 60	1220 x 150 x 60	1220 x 150 x 60	1220 x 150 x 80	1370 x 175 x 80
7	Mast tilt angle	FR/RR	6/12	6/12	6/12	6/12	6/12
8	Minimum turning radius	mm	3300	3300	3370	3370	3950
9	Minimum right angle stacking aisle width	mm	5220	5220	5290	5310	5977
10	Minimum right angle aisle width	mm	2960	2960	3100	3100	3540
11	Minimum ground clearance	mm	200	200	200	200	245
12	Height of overhead guard	mm	2450	2450	2450	2450	2560
13	Overhang(FR)	mm	620	620	620	640	727
14	Maximum travel speed	Full load	km/h	26	26	26	26
15	Maximum lift speed	Full load	mm/s	460	460	430	400
16	Maximum drawbar pull	Full load	KW	53	53	53	60
17	Gradeability		%	30	28	22	20
18	Overall length	Without forks	mm	3450	3450	3560	3588
19	Overall width		mm	1995	1995	1995	1995
20	Fork height at maximum lift(with backrest)		mm	4420	4420	4420	4420
21	Mast height		mm	2500	2500	2500	2500
22	Tires	Front wheel		8.15-15-14PR	8.15-15-14PR	8.15-15-14PR	8.15-15-18PR
23		Rear wheel		8.15-15-14PR	8.15-15-14PR	8.15-15-14PR	8.15-15-18PR
24	Wheelbase		mm	2250	2250	2250	2250
25	Tread	Front wheel/rear wheel	mm	1470/1700	1470/1700	1470/1700	1470/1700
26	Self weight	Without load	Kg	8160	8640	9460	10460
27	Battery	Voltage/capacity	V/Ah	24/160	24/160	24/160	24/160
28	Engine	Model		CA4DF3	CA4DF3	CA4DF3	CA4DF3
29		Rated output	kw/r.p.m	85/2200	85/2200	85/2200	85/2200
30		Rated torque	Nm/r.p.m	460/1400-1500	460/1400-1500	460/1400-1500	460/1400-1500
31		Bore x stroke	mm	110 x 125	110 x 125	110 x 125	110 x 125
32		Number of cylinders		4	4	4	4
33		Displacement	L	4.75	4.75	4.75	4.75
34	Fuel tank capacity	L	110	110	110	110	
35	Transmissions(FWD/RWD)		2/2 Manual shift	2/2 Manual shift	2/2 Manual shift	2/2 Manual shift	
36	Operating pressure	Mpa	19.5	19.5	19.5	19.5	
37	Tire type(FR/RR)		Pneumatic	Pneumatic	Pneumatic	Pneumatic	
38	Number of wheels(FR/RR)	Pcs	4/2	4/2	4/2	4/2	
39	Lowering speed(full load)	mm/s	460	540	540	540	
40	Lowering speed(no load)	mm/s	390	470	470	470	
41	Axle load distribution(full load)(FR/RR)	kg	11844/1316	13186/1464	14814/1646	16614/1846	
42	Axle load distribution(fno load)(FR/RR)	kg	3264/4896	3456/5184	3784/5676	4184/6276	

Calculation of minimum right angle stacking aisle width: Pallet size: 1100mm x 1100mm, total clearance(FR/RR):100mm

## DIMENSIONAL DRAWING

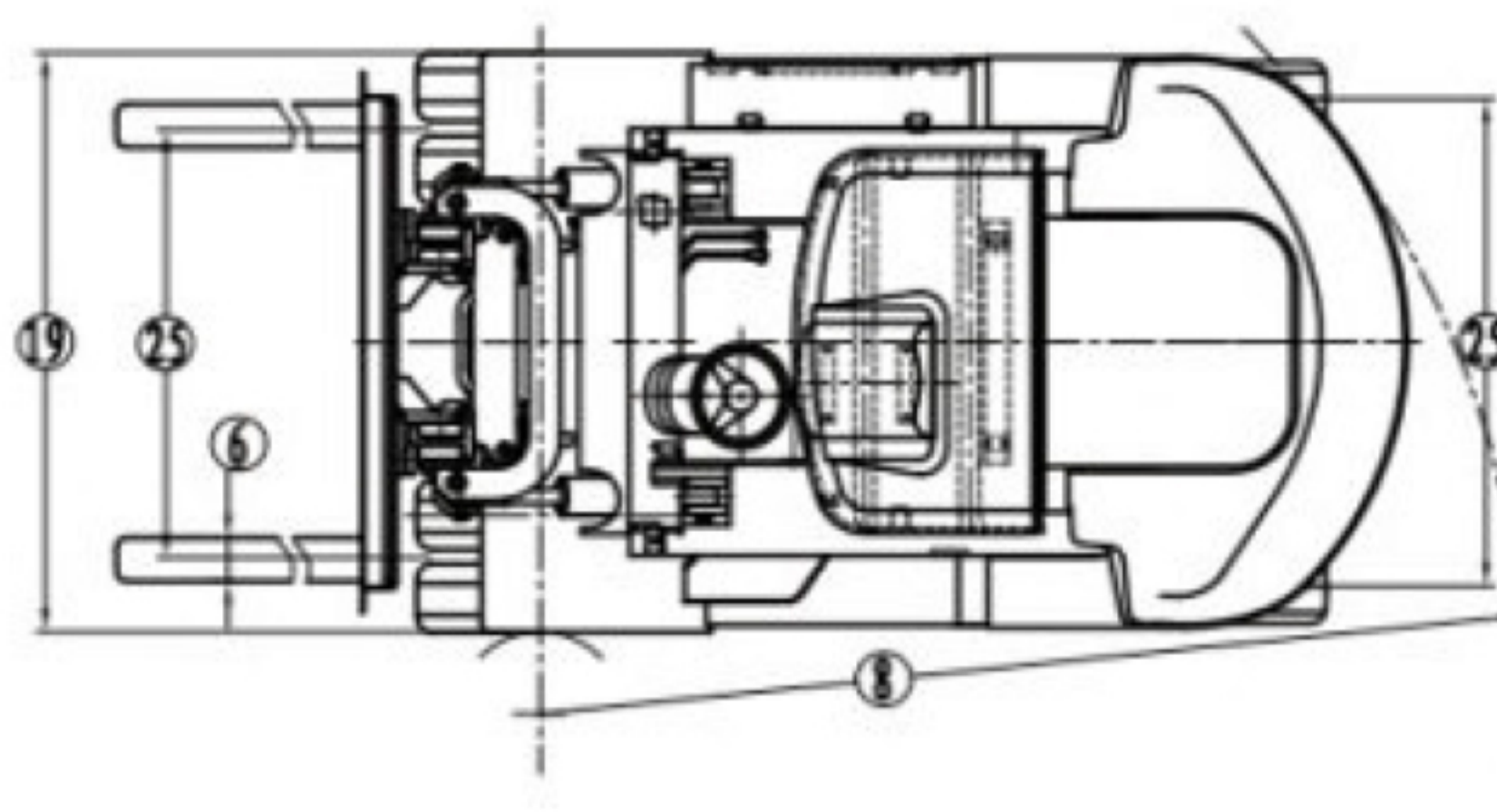
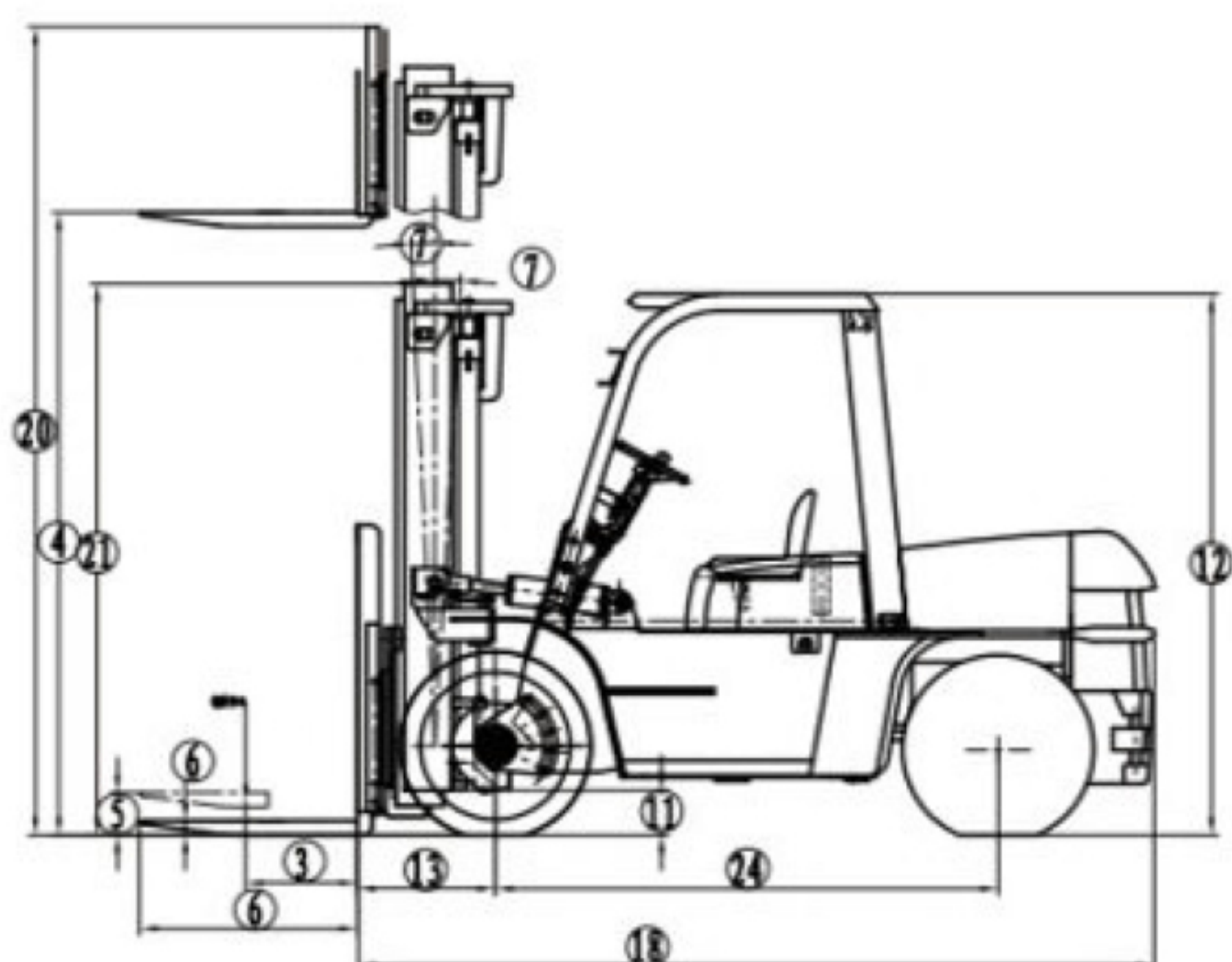



## LOAD CAPACITY

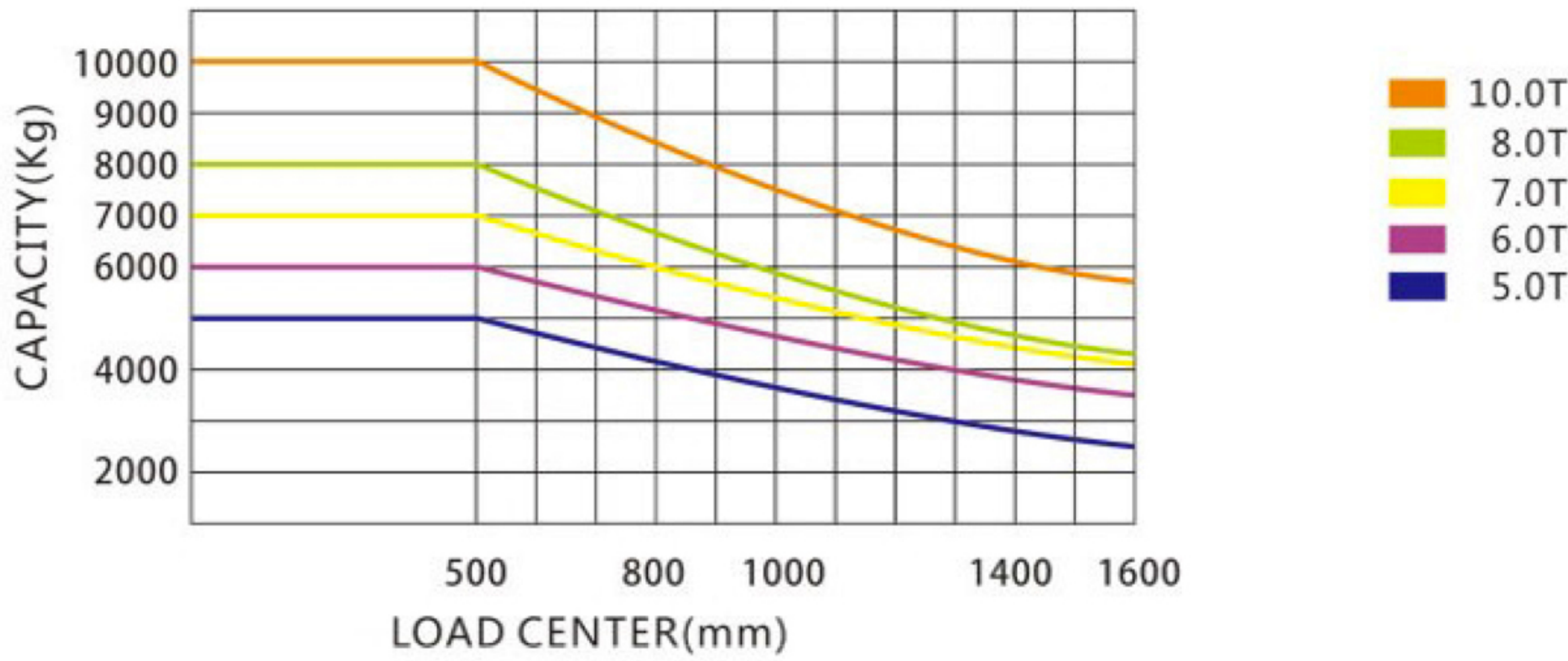

**Note:** the vertical axis represents the CAPACITY and the horizontal axis represents the LOAD CENTER. The calculation of LOAD CENTER starts with the frontage of fork. The basic point of standard load refers to the center of a cube with load side 1000mm long. The CAPACITY will drop if the mast tilts forwards, a non-standard fork is adopted or the load width is excessive. The CAPACITY at the LOAD CENTER could be timely learnt of through the load curve.

## STANDARD EQUIPMENT

- Standard forks
- Standard seat
- Charging indication
- Backrest
- Backup light
- Back-up buzzer
- Side mirror
- Light switch
- Lamp bracket
- Electric horn
- 2-piece selector valve
- Engine choke
- Direction switch
- Combination taillight
- Rain cover of overhead guard
- Durable rib tire
- Hour meter
- Neutral indicator
- Air cleaner clogging alarm
- WFOV mast
- Cable type parking brake
- Lift/tilt lever
- Lift circuit governor valve
- Drawbar pin
- Headlight
- Tilt adjustable steering wheel
- Full hydraulic power steering
- Overhead air intake system
- Handle
- Coolant temperature gauge
- Tool kit
- Rubber pedal pad
- Pointer type instrument cluster
- LCD instrument cluster
- Hydraulic return filter element
- Hydraulic suction filter element
- Hydraulic oil scale
- Oil pressure alarm
- Key switch
- Brake

## OPTIONS EQUIPMENT

- 3rd shifter
- Boom
- Windshield
- 2(3)-section full free mast
- Deluxe seat
- High exhaust pipe
- Lengthened forks
- Lengthened fork cover
- Cab
- Cab heater
- Jib
- Hinged forks
- 3-section full free mast
- Solid tire
- Dual air filter
- Rotating beacon
- User specified color
- Paper roll clamp
- Small fan

## ENGINE TYPE SELECTION AND PARAMETERS

Manufacturer	Power type	Model	Number of cylinders	Bore x stroke mm	Total displacement L	Rated output/RPM Kw/r.p.m	Rated torque/RPM Nm/r.p.m	Emission standard	Applicable forklift truck					
									CPCD50H	CPCD60H	CPCD70H	CPCD80H	CPCD100H	
Mitsubishi, Japan	Diesel	S6S-T	6	94*120	4.996	67.7/2300	293/1700	EU stage IIIA						
Xichai, China	Diesel	CA6110	6	110*125	7.127	83/2000	450/1500	Nationa Stage II						
Yuchai, China	Diesel	YC6B125	6	108*125	6.87	92/2200	463/1400-1600	Nationa Stage II						
Isuzu, Japan	Diesel	A-6BG1QC-02	6	105*125	5.785	82.4/2000	416.8/1500	Nationa Stage I						
Perkins, UK	Diesel	1104C-44T	4	105*127	4.4	74.5/2300	418/1400	EU stage II						
Cummins, America	Diesel	QSB3.8	4	102*115	3.8	86/2200	470/1100-1700	EU stage IIIA						
Cummins, America	Diesel	QSB4.5	4	107*124	4.5	82/2200	488/1500	EU stage IIIA						
Xichai, China	Diesel	CA4DF3	4	110*125	4.75	85/2200	460/1400-1500	Nationa Stage III						
PSI, America	Gasoline & LPG	PSI4.3	6	101*88	4.3	LPG:76/2300; Gasoline: 70/2300	LPG:324/1700; Gasoline: 287/1700							

## SPECIFICATION TABLE OF FORKS

Applicable models	Standard	Width W mm	Thickness T mm	Length series										Mounting class
	LxWxT			L mm										
	mm	1220	1370	1520	1670	1820	1970	2120	2270	2420	2570			
5-7t	1220x150x60	150	60	1220	1370	1520	1670	1820	1970	2120	2270	2420	2570	IV
8t	1220x150x80	170	70	1220	1370	1520	1670	1820	1970	2120	2270	2420		IV
10t	1370x175x80	175	80	1220	1370	1520	1670	1820	1970	2120	2270	2420	2570	IV



