

JAC



JAC FORKLIFT

3.5T Rough Terrain Forklift

CPC35R / CPCD35R



JAC HEAVY DUTY IMPORT & EXPORT CO.,LTD





MATERIAL HANDLING EXPERTS FROM AUTOMOTIVE QUALITY



contact@gmm-mg.com
Route du Pape Alarobia (face sanifer)
+261 32 03 111 33 / +261 32 03 111 34 / +261 32 03 111 36



Move forward

Highlights of 3.5T Rough Terrain Forklift

Five Highlights

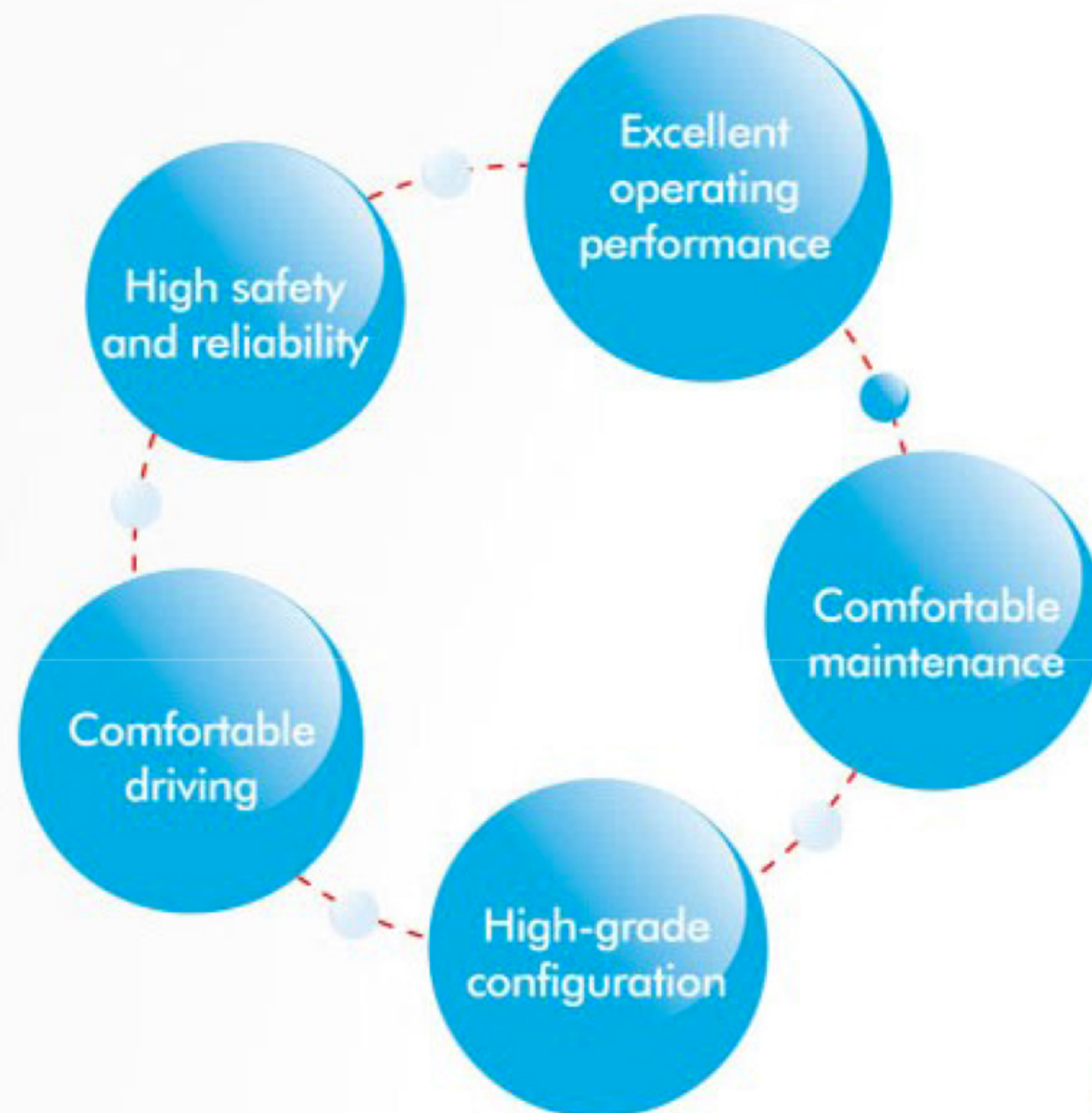

No.1 High-grade configuration

◆ Excellent inlet system design

Inlet system provided with double air filters that prolong service life of engine while the working condition is poor.



◆ Independent radiator for engine and torque converter improves heat balance of the system and prolongs service life.

No.2 Excellent operating performance

◆ High performance engine

Regular YANMAR 4TNE98 engine featuring advanced technology, stable performance and has reached EURO III emission regulation.

◆ load sensing hydraulic system

Load-sensitive hydraulic system ensures the fork to lift with full load while the engine is running idly so as to reduce fuel consumption.

◆ Regular LED for outdoor operation at night

Double LED headlamp;

Single LED rear light;

Rear combined LED lights;

Warning lights;

Elegant design and applicable to field operation where the lighting is poor.

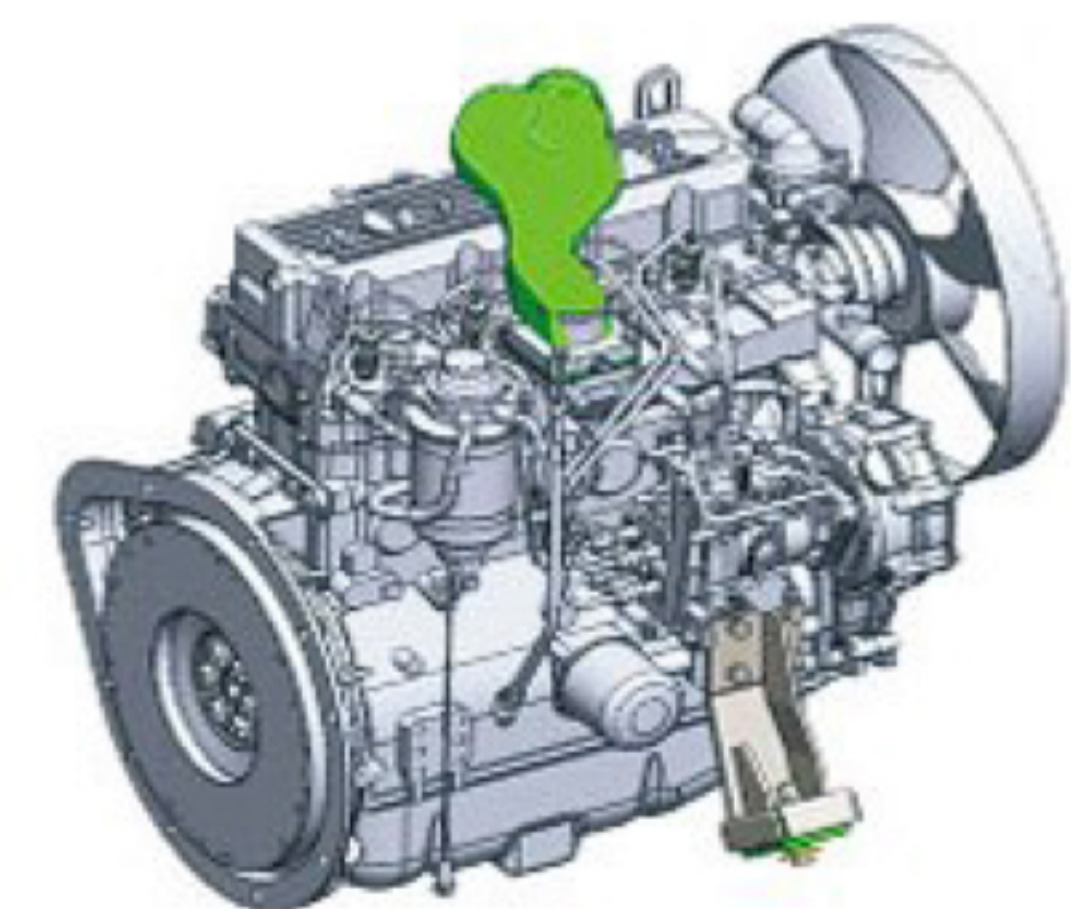



◆ **Large ground clearance**

Minimum ground clearance reaches 263mm.

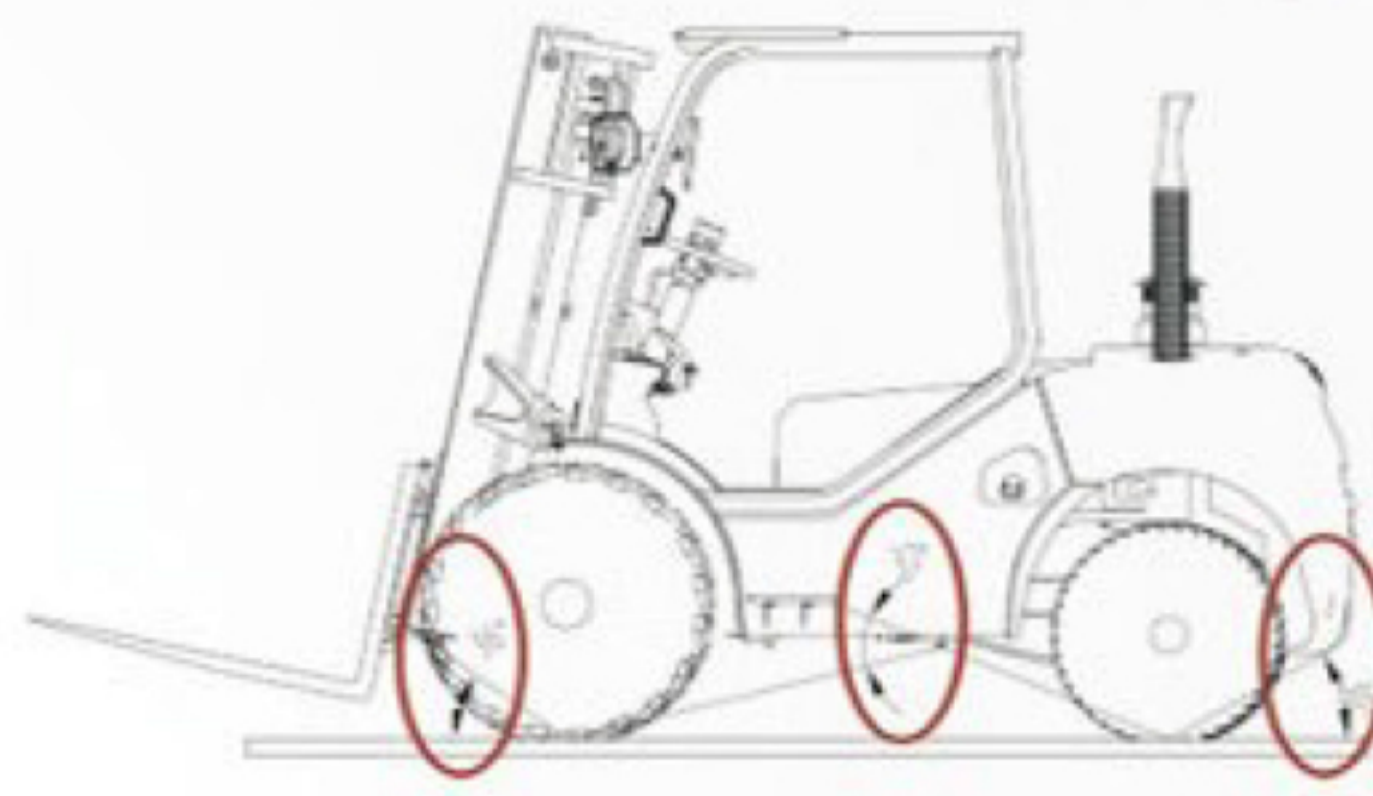

◆ **Off-road performance**

The driving wheels feature large diameter, deep pattern and wide section for excellent off-road performance.

◆ **Self-rescue**

The transmission case is provided with a differential lock for self-rescue in case the machine is trapped muddy ground.

No.3 High safety and reliability

◆ **Integrated cover of fuel and oil to reduce leak.**



◆ **OPS seat**

The forklift fails in moving and the mast fails in rising once the driver has left the seat.



◆ **Manual brake for safety**

The forklift will not move still the manual brake has been activated.

No.4 Comfortable driving

◆ **Low vibration**

Industry-leading three-level shock absorption.

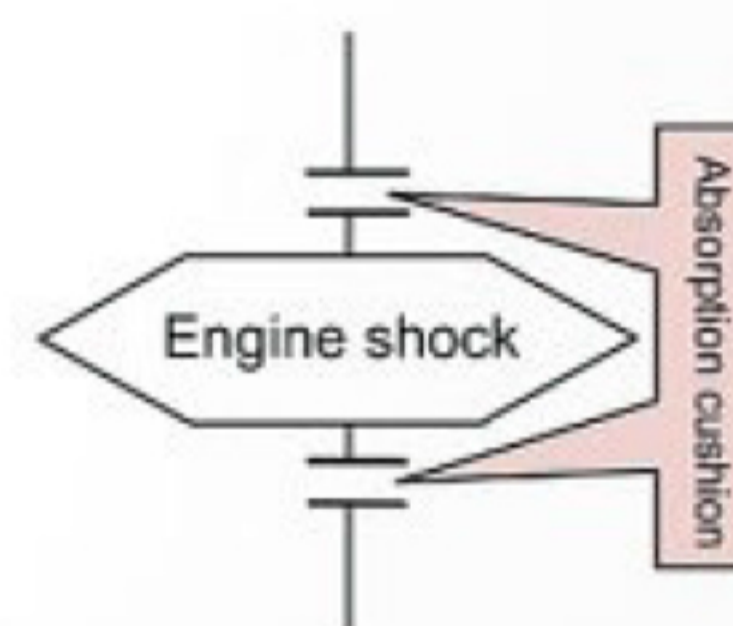

Level-1 shock absorption

Level-2 shock absorption

Level-3 shock absorption

No.5 Convenient maintenance

◆ **Return oil filter is located outside of the body for easy replacement and washing.**



◆ **Broad visual field**



Wide mast



Grid roof



◆ **Easy operation**

Electro-hydraulic directional valve and stepless speed change.



2M WFOV BASIC MAST

Lift height	Load capacity				Overall height of mast									
	CPC(D)35R × 2		CPCD35R × 4J		CPC(D)35R × 2					CPCD35R × 4J				
					Forks(on the ground)	Fully extended		Mast tilt angle		Forks(on the ground)	Fully		Mast tilt angle	
	Front	Single tire	Dual tire	Single tire		Dual tire	With backrest	Without backrest	FR/RR		FR/RR	With backrest	FR/RR	FR/RR
mm	kg	kg	kg	kg	mm	mm	mm	°	°	mm	mm	°	°	
2000	3500	3500	3500	3500	1755	3400	2870	6/12		1980	3390	10/12	10/12	
2300	—	—	—	—	1905	3700	3170	6/12		—	—	—	—	
2500	3500	3500	3500	3500	2005	3900	3370	6/12		2230	3890	10/12	10/12	
2700	3500	3500	3500	3500	2105	4100	3570	6/12		2330	4090	10/12	10/12	
3000	3500	3500	3500	3500	2255	4400	3870	6/12		2480	4390	10/12	10/12	
3300	3500	3500	3500	3500	2405	4700	4170	6/12		2630	4690	10/12	10/12	
3500	3500	3500	3500	3500	2505	4900	4370	6/12		2730	4890	10/12	10/12	
3600	3500	3500	3500	3500	2555	5000	4470	6/12		2830	5090	6/6	10/12	
3700	3500	3500	3500	3500	2605	5100	4570	6/12		3030	5440	6/6	10/12	
4000	3500	3500	3300	3500	2805	5400	4870	6/12		3155	5690	6/6	10/12	
4250	3300	3500	3050	3500	2930	5650	5120	6/12		3280	5940	6/6	10/12	
4500	3050	3500	2800	3300	3055	5900	5370	6/12		3405	6190	6/6	6/6	
5000	2600	3150	2600	3150	3305	6400	5870	6/6		3530	6440	6/6	6/6	
5500	—	2850	—	2850	3605	6900	6370	3/6		3830	6990	6/6	3/6	
6000	—	2850	—	2500	3855	7400	6870	3/6		4080	7490	6/6	3/6	

STANDARD EQUIPMENT

- Backrest
- Backup light
- Back-up buzzer
- Side mirror
- Light switch
- Lamp bracket
- Electric horn
- 2-piece selector valve
- Engine choke
- Direction switch
- Combination taillight
- Rain cover of overhead guard
- Durable rib tire
- Hour meter
- Air cleaner clogging alarm
- WFOV mast
- Cable type parking brake
- Lift/tilt lever
- Lift circuit governor valve
- Drawbar pin
- Headlight
- Tilt adjustable steering wheel
- Tilt circuit self-locking valve
- Full hydraulic power steering
- Overhead air intake system
- Handle
- Coolant temperature gauge
- Tool kit
- Rubber pedal pad
- Cyclone air cleaner
- Pointer type instrument cluster
- LCD instrument cluster
- Hydraulic return filter element
- Hydraulic suction filter element
- Hydraulic oil scale
- Oil pressure alarm
- Key switch
- Brake
- Turn signal light
- OPS seat
- Rocker type parking brake
- Rear headlight
- Two constant displacement motor
- Variable displacement piston pumps
- Rocker switch 2WD/4WD
- Rocker switch large / small displacement of drive pump
- Integrated handle
- Tilttable cab
- Four off road herringbone tires
- Independent hydraulic oil radiator

OPTIONS EQUIPMENT

- Side shifter
- Boom
- Windshield
- Hook
- 2(3)-section full free mast
- Deluxe seat
- High exhaust pipe
- Lengthened forks
- Lengthened fork cover
- Cab
- Cab heater
- Exhaust purification muffler
- Muffler with spark arrester
- Jib
- Hinged forks
- 3-section full free mast
- Solid tire
- Dual air filter
- Rotating beacon
- User specified color
- Paper roll clamp
- Colored tire(white, green)
- Small fan

ENGINE TYPE SELECTION AND PARAMETERS

No.	Manufacturer	Power type	Model	Number of cylinders	Bore x stroke	Total displacement	Rated output/RPM	Rated torque/RPM	Emission standard
					mm	L	Kw/r.p.m	Nm/r.p.m	
1	YANMAR, Japan	Diesel	4TNE 98	4	98 × 110	3.319	42.1/2300	177.6 ~ 196.3/1700 ± 100	EU stage III, Tier3
2	Xinchang, China	Diesel	4D32G31	4	98 × 105	3.168	36.8/2500	186/1600-1800	National stage III

SPECIFICATION TABLE OF FORKS

Width	Thickness	Length							Mounting class		
		mm									
125	50	770	920	1070	1220	1370	1520	1670	1820	1970	III



LOAD CAPACITY

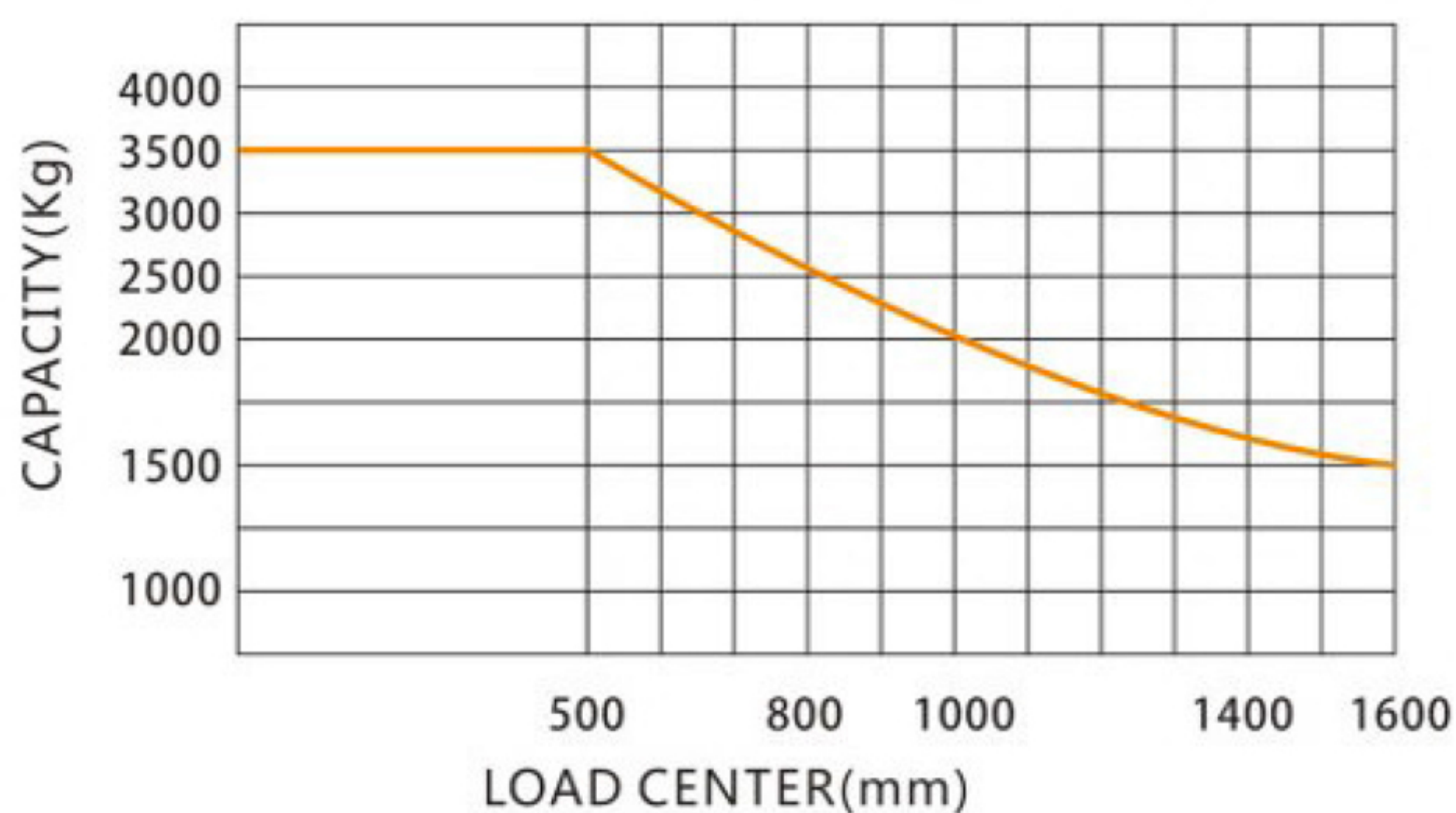

3.5T

Note: the vertical axis represents the CAPACITY and the horizontal axis represents the LOAD CENTER. The calculation of LOAD CENTER starts with the frontage of fork. The basic point of standard load refers to the center of a cube with load side 1000mm long. The CAPACITY will drop if the mast tilts forwards, a non-standard fork is adopted or the load width is excessive. The CAPACITY at the LOAD CENTER could be timely learnt of through the load curve.



3.5T ROUGH TERRAIN FORKLIFT



contact@gmm-mg.com
 Route du Pape Alarobia (face sanifer)
 +261 32 03 111 33 / +261 32 03 111 34 / +261 32 03 111 36



Move forward

SPECIFICATIONS

Model			CPC35R x 2	CPCD35R x 2	CPCD35R x 4J
1	Power type		Diesel	Diesel	Diesel
2	Rated load		3500	3500	3500
3	Load center distance		500	500	500
4	Lift height		3000	3000	3000
5	Free lift height		244	244	70
6	Fork size	L x W x T	1070 x 125 x 50	1070 x 125 x 50	1220 x 125 x 50
7	Mast tilt angle	FR/RR	10/12	10/12	10/12
8	Minimum turning radius		2870	2870	4615
9	Minimum right angle stacking aisle width		4660	4660	6735
10	Minimum right angle aisle width		2820	2820	4200
11	Minimum ground clearance		263	263	380
12	Height of overhead guard		2285	2285	2400
13	Overhang(FR)		587	587	700
14	Maximum travel speed	Full load	23	22	22
15	Maximum lift speed	Full load	530	530	450
16	Maximum drawbar pull	Full load	20	19	36
17	Gradeability		20	20	36
18	Overall length	Without forks	3047	3047	3250
19	Overall width		1610	1610	2000
20	Fork height at maximum lift(with backrest)		4400	4400	4700
21	Mast height		2253	2253	2510
22	Tires	Front wheel	14-17.5 14PR ESK308	14-17.5 14PR ESK308	405/70-20
23		Rear wheel	27 x 10-12 14PR	27 x 10-12 14PR	10.0/75-15.3
24	Wheelbase		1880	1880	1950
25	Tread	Front wheel/rear wheel	1250/1220	1250/1220	1570/1430
26	Self weight	Without load	5260	5240	5750
27	Battery	Voltage/capacity	12/105	12/105	12/120
28	Engine	Model	YANMAR 4TNE 98	YANMAR 4TNE 98	YANMAR 4TNE 98
29		Rated output	42.1/2300	42.1/2300	42.1/2300
30		Rated torque	177.6 - 196.3/1700 ± 100	177.6 - 196.3/1700 ± 100	177.6 - 196.3/1700 ± 100
31		Bore x stroke	98 x 110	98 x 110	98 x 110
32		Number of cylinders	4	4	4
33		Displacement	3.319	3.319	3.319
34	Fuel tank capacity		52	52	83
35	Transmissions(FWD/RWD)		2/2 manual shift	1/1 electro-hydraulic directional valve	2/2 electro-hydraulic directional valve
36	Operating pressure		18.5	18.5	20
37	Tire type(FR/RR)		Pneumatic	Pneumatic	Pneumatic
38	Number of wheels(FR/RR)		2/2	2/2	2/2
39	Lowering speed(full load)		355	355	380
40	Lowering speed(no load)		360	360	360
41	Axle load distribution(full load)(FR/RR)		7700/1060	7700/1060	8325/925
42	Axle load distribution(no load)(FR/RR)		2060/3200	2040/3200	2300/3450

DIMENSIONAL DRAWING

